

PZP H50

Codice 000036

Dispositivo di ancoraggio di altezza 50cm certificato EN 795 e CEN/TS 16415 tipo A e C in acciaio zincato a caldo con base di fissaggio piana 30cm x 30cm e con 4 asole per una massima comodità di installazione.

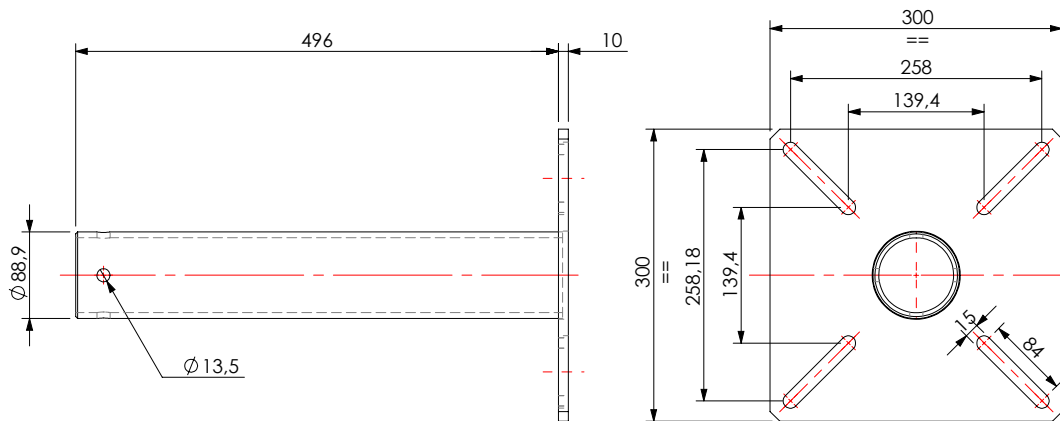

Materiale	S235 Zincato a Caldo
Dimensioni (mm)	506 x 300 x 300
Peso (kg)	14,35
Codice doganale	73269098
EAN code	8055773300743

CERTIFICAZIONI

	A	C
UNI EN 795:2012	1	1
UNI 11578:2015	-	4
CEN/TS 16415:2013	2	4

LUNGHEZZA	min 5 max 120
CAMPATA	min 5 max 20

Scopri la linea prodotto:



PZI H50

Codice 000185

Dispositivo di ancoraggio di altezza 50cm certificato EN 795 e CEN/TS 16415 tipo A e C in acciaio zincato a caldo con base di fissaggio inclinata 30cm x 30cm e con 4 asole per una massima comodità di installazione.

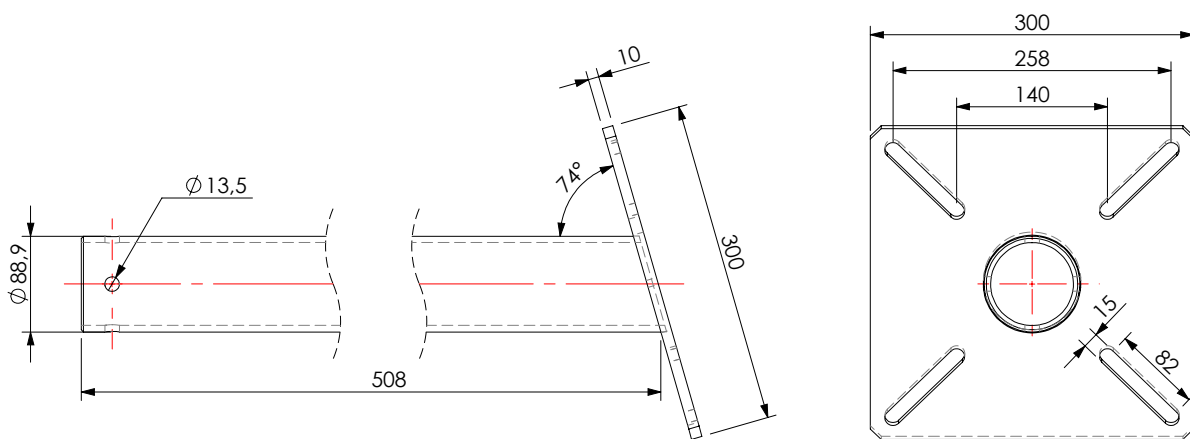

Materiale	S235 Zincato a Caldo
Dimensioni (mm)	546 x 300 x 300
Peso (kg)	11,8
Codice doganale	73269098
EAN code	8055773300767

CERTIFICAZIONI

	A	C
UNI EN 795:2012	1	1
UNI 11578:2015	1	4
CEN/TS 16415:2013	2	4

LUNGHEZZA	min 5 max 120
CAMPATA	min 5 max 20

Scopri la linea prodotto:



PZC H50

Codice 000186

Dispositivo di ancoraggio di altezza 50cm certificato EN 795 e CEN/TS 16415 tipo A e C in acciaio zincato a caldo con base di fissaggio a colmo 30cm x 30cm e con 4 asole per una massima comodità di installazione.

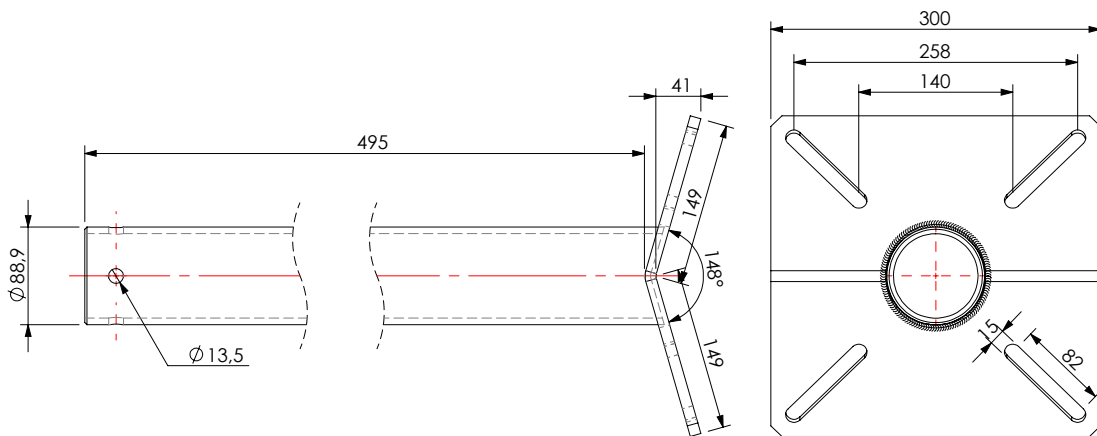

Materiale	S235 Zincato a Caldo
Dimensioni (mm)	500 x 300 x 300
Peso (kg)	12,2
Codice doganale	73269098
EAN code	8055773300750

CERTIFICAZIONI

	A	C
UNI EN 795:2012	1	1
UNI 11578:2015	-	4
CEN/TS 16415:2013	2	4

LUNGHEZZA	min 5 max 120
CAMPATA	min 5 max 20

Scopri la linea prodotto:



PZL H50

Codice 000187

Dispositivo di ancoraggio di altezza 50cm certificato EN 795 e CEN/TS 16415 tipo A e C in acciaio zincato a caldo con base di fissaggio piana per travi di legno 40cm x 16cm e 8 fori idonei per barre filettate o viti da legno.

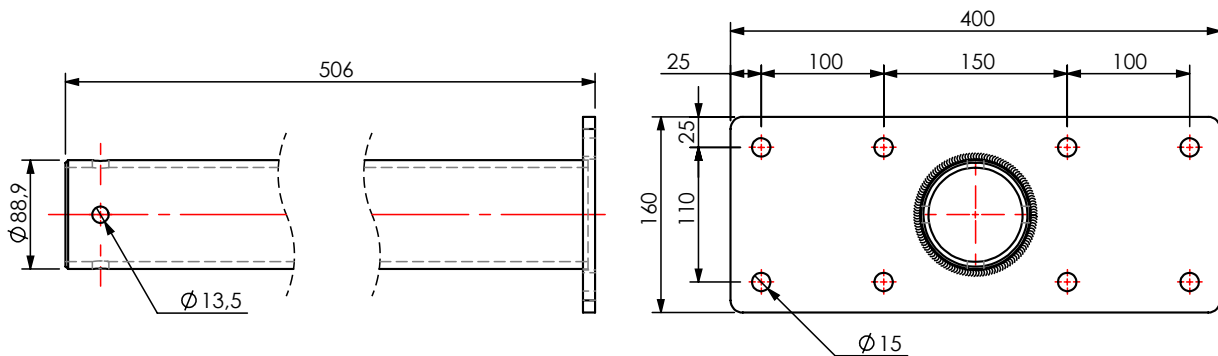

Materiale	S235 Zincato a Caldo
Dimensioni (mm)	500 x 160 x 400
Peso (kg)	10,4
Codice doganale	73269098
EAN code	8055773300774

CERTIFICAZIONI

	A	C
UNI EN 795:2012	1	1
UNI 11578:2015	-	4
CEN/TS 16415:2013	2	4

LUNGHEZZA	min 5 max 120
CAMPATA	min 5 max 20

Scopri la linea prodotto:

